

C.I.P.**6 mm D.B.G.**

TAB.

I

Date

16-05-18

Revision

Country of Origin: IT

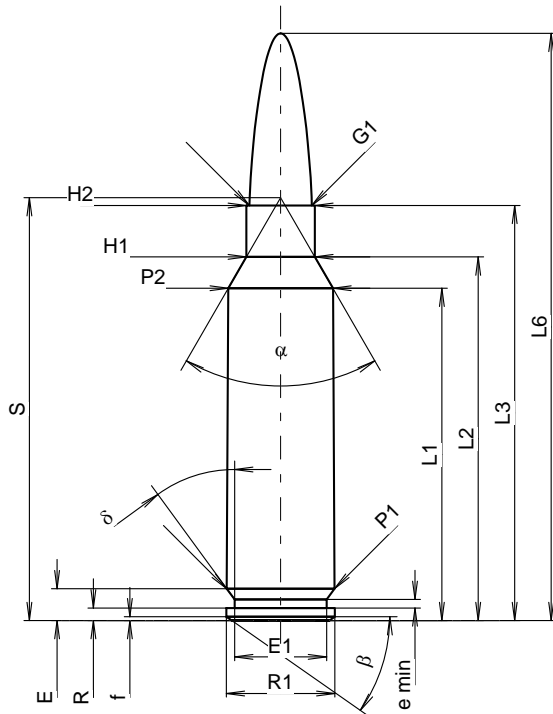
**CARTRIDGE MAXI****Lengths**

L1 ¹⁾	=	32.82	-0.20
L2 ¹⁾	=	35.91	-0.20
L3 ¹⁾	=	41.00	
L4	=		
L5	=		
L6	=	58.00	

Case Head

R	=	1.24	
R1	=	10.72	
R3	=		
E	=	3.15	
E1	=	9.09	
e min	=	0.84	
delta	=	36°	
f	=	0.38	
beta	=	35°	

Powder Chamber

P1	=	10.65	
P2 ¹⁾ *	=	10.34	-0.20

Junction Cone

alpha *	=	60°	
S *	=	41.77	
r1 min	=		
r2	=		

Collar

H1 *	=	6.77	
H2 ¹⁾	=	6.77	

Projectile

G1 ¹⁾	=	6.17	
G2	=		
F	=		
L3+G ¹⁾	=	44.84	

Pressures (Energies)**Method Transducer**

Pmax	=	4150 bar	
PK	=	4773 bar	
PE	=	5188 bar	
M	=	25.00	
EE	=	2100 Joule	

Miscellaneous Dimensions

Fe ¹⁾³⁾	=	0.10	
delta L	=		

CHAMBER MINI**Lengths**

L1	=	32.91	
L2	=	36.02	
L3 ¹⁾	=	41.23	

Breech

R	=		
R1	=	10.80	
R2	=		
R3	=		
r	=		

Powder Chamber

E	=	3.18	
P1 ¹⁾	=	10.68	
P2 *	=	10.37	

Junction Cone

alpha ¹⁾ *	=	60°	
S *	=	41.89	
r1 max	=		
r2	=		

Collar

H1 *	=	6.78	
H2 ¹⁾	=	6.78	

Commencement of Rifling

G1 ¹⁾ *	=	6.18	
G ¹⁾	=	3.84	
alpha 1	=	90°	
h	=	0.30	
s *	=	0.32	
i ¹⁾ *	=	1°18'07"	
w	=		

Barrel

F ¹⁾ *	=	6.02	
Z ¹⁾	=	6.17	

Grooves

b	=	1.73	
N	=	6	
u	=	254.00	
Q	=	29.25	mm ²

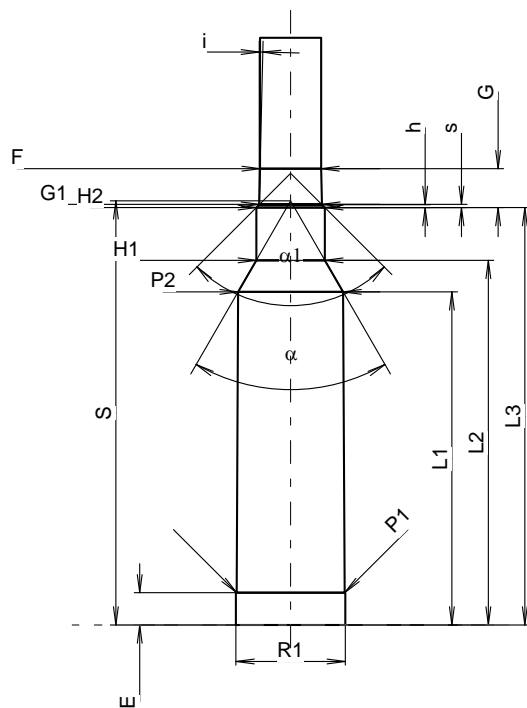

Scale 1.34:1

Dimensions in << mm >>
Dimensions and Tolerances for Proof Barrels
see Appendix CR1.

Notes: 1) Check for safety reasons
3) Headspace on Shoulder
* Basic dimensions