

C.I.P.

300 Win. Short Mag.

Country of Origin: US

TAB. I

Date 02-01-22

Revision 08-09-23

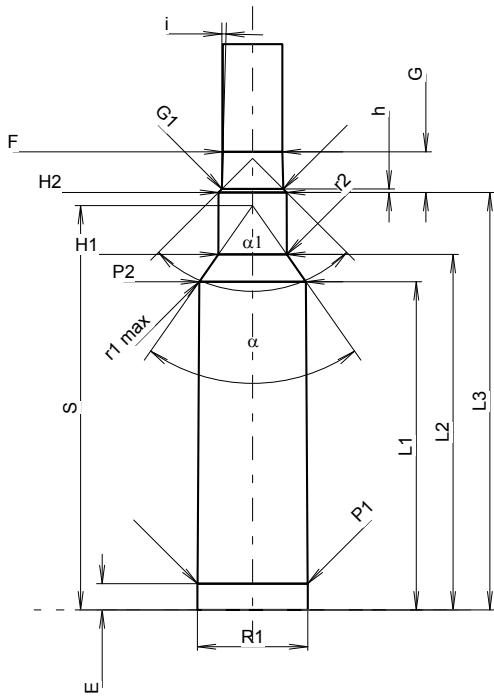
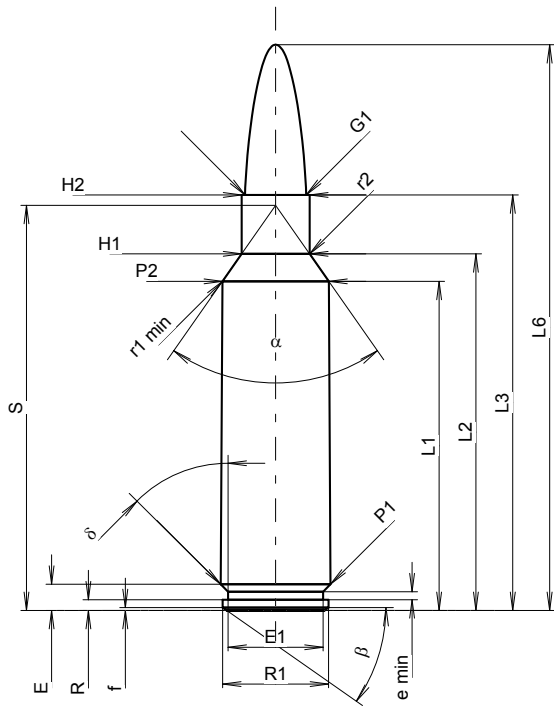

Scale 1.03:1

Dimensions in << mm >>
Dimensions and Tolerances for Proof Barrels
see Appendix CR 1.

CARTRIDGE MAXI

Lengths

L1 ¹⁾	=	42.25	-0.20
L2 ¹⁾	=	45.77	-0.20
L3 ¹⁾	=	53.34	
L4	=		
L5	=		
L6	=	72.64	

Case Head

R	=	1.37	
R1	=	13.59	
R3	=		
E	=	3.35	
E1	=	12.19	
e min	=	1.02	
delta	=	45°	
f	=	0.36	
beta	=	35°	

Powder Chamber

P1	=	14.12	
P2 ¹⁾ *	=	13.67	-0.20

Junction Cone

alpha *	=	70°	
S *	=	52.01	
r1 min	=	1.27	
r2	=	2.54	

Collar

H1 *	=	8.74	
H2 ¹⁾	=	8.74	

Projectile

G1 ¹⁾	=	7.85	
G2	=		
F	=		
L3+G ¹⁾	=	58.56	

Pressures (Energies)

Method Transducer

Pmax	=	4400 bar	
PK	=	5060 bar	
PE	=	5500 bar	
M	=	25.00	
EE	=	5250 Joule	

Miscellaneous Dimensions

Fe ¹⁾³⁾	=	0.10	
delta L	=	0.10	

CHAMBER MINI

Lengths

L1	=	42.13	
L2	=	45.63	
L3 ¹⁾	=	53.59	

Breech

R	=		
R1	=	14.19	
R2	=		
R3	=		
r	=		

Powder Chamber

E	=	3.35	
P1 ¹⁾	=	14.15	
P2 *	=	13.70	

Junction Cone

alpha ¹⁾ *	=	70°	
S *	=	51.91	
r1 max	=	1.27	
r2	=	3.05	

Collar

H1 *	=	8.79	
H2 ¹⁾	=	8.76	

Commencement of Rifling

G1 ¹⁾ *	=	7.87	
G ¹⁾	=	5.22	
alpha 1 *	=	90°	
h	=	0.45	
s	=		
i ¹⁾ *	=	1°30'	
w	=		

Barrel

F ¹⁾ *	=	7.62	
Z ¹⁾	=	7.82	

Grooves

b	=	4.49	
N	=	4	
u	=	254.00	
Q	=	47.52	mm ²

Notes: 1) Check for safety reasons
3) Headspace on Shoulder
* Basic dimensions