

C.I.P.

8 x 68 S

Country of Origin: DE

TAB. I

Date 84-06-14

Revision 06-09-19

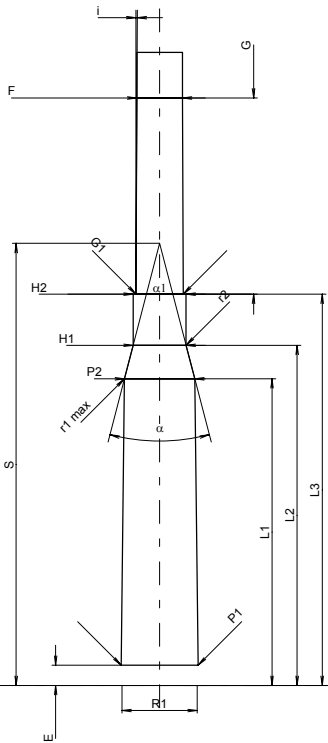
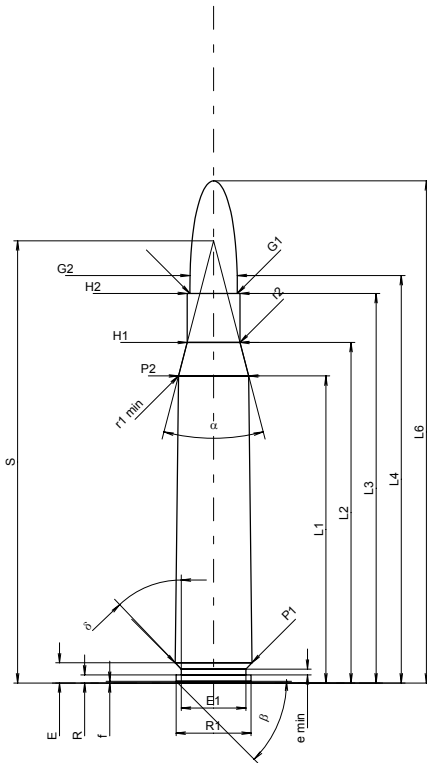

Scale 1:1.31

Dimensions in << mm >>
Dimensions and Tolerances for Proof Barrels
see Appendix CR 1.

CARTRIDGE MAXI

Lengths

L1 ¹⁾ *	=	53.20	-0.20
L2 ¹⁾ *	=	59.00	-0.20
L3 ¹⁾	=	67.50	
L4	=	70.60	
L5	=		
L6	=	87.00	

Case Head

R	=	1.40	
R1	=	13.00	
R3	=		
E	=	3.50	
E1	=	11.20	
e min	=	1.00	
delta	=	43°42'	
f	=	0.30	
beta	=	45°	

Powder Chamber

P1	=	13.30	
P2 ¹⁾ *	=	12.15	-0.20

Junction Cone

alpha	=	29°05'34"	
S	=	76.61	
r1 min	=	0.50	
r2	=	0.50	

Collar

H1 [*]	=	9.14	
H2 ¹⁾	=	9.14	

Projectile

G1 ¹⁾	=	8.22	
G2	=	8.18	
F	=		
L3+G ¹⁾	=	101.50	

Pressures (Energies)

Method Transducer

Pmax	=	4400 bar	
PK	=	5060 bar	
PE	=	5500 bar	
M	=	25.00	
EE	=	5975 Joule	

Miscellaneous Dimensions

Fe ¹⁾	=	0.10	
delta L	=		

CHAMBER MINI

Lengths

L1 [*]	=	53.14	
L2 [*]	=	58.94	
L3 ¹⁾	=	67.80	

Breech

R	=	1.40	
R1	=	13.05	
R2	=		
R3	=		
r	=		

Powder Chamber

E	=	3.50	
P1 ¹⁾	=	13.33	
P2 [*]	=	12.18	

Junction Cone

alpha ¹⁾	=	29°05'34"	
S	=	76.61	
r1 max	=	0.50	
r2	=	0.50	

Collar

H1 [*]	=	9.17	
H2 ¹⁾	=	9.16	

Commencement of Rifling

G1 ¹⁾ *	=	8.23	
G ¹⁾ *	=	34.00	
alpha l	=	180°	
h	=		
s	=		
i ¹⁾	=	0°17'11"	
w	=		

Barrel

F ¹⁾ *	=	7.89	
Z ¹⁾	=	8.20	

Grooves

b	=	4.40	
N	=	4	
u	=	280.00	
Q	=	51.78	mm ²

Notes: 1) Check for safety reasons
* Basic dimensions