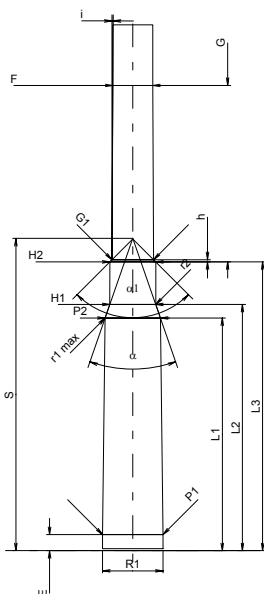
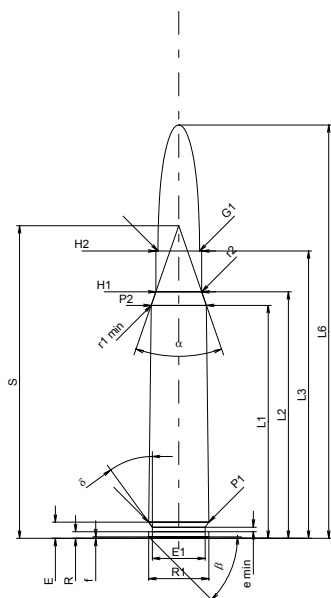

C.I.P.

8 x 57 IS

TAB. I
Date 84-06-14

Country of Origin: DE

Revision 02-05-15

Scale 1:1.5

Dimensions in << mm >>
 Dimensions and Tolerances for Proof Barrels
 see Appendix CR 1.

CARTRIDGE MAXI
Lengths

L1 ¹⁾ *	=	46.20	-0.20
L2 ¹⁾ *	=	48.90	-0.20
L3 ¹⁾	=	57.00	
L4	=		
L5	=		
L6	=	82.00	

Case Head

R	=	1.30	
R1	=	11.95	
R3	=		
E	=	3.19	
E1	=	10.50	
e min	=	0.90	
delta	=	36°	
f	=	0.30	
beta	=	45°	

Powder Chamber

P1	=	11.94	
P2 ¹⁾ *	=	10.95	-0.20

Junction Cone

alpha	=	38°12'06"	
S	=	62.01	
r1 min	=	0.50	
r2	=	0.50	

Collar

H1 *	=	9.08	
H2 ¹⁾	=	9.08	

Projectile

G1 ¹⁾	=	8.22	
G2	=		
F	=		
L3+G ¹⁾	=	92.00	

Pressures (Energies)
Method Transducer

Pmax	=	3900 bar	
PK	=	4485 bar	
PE	=	4875 bar	
M	=	25.00	
EE	=	4300 Joule	

Miscellaneous Dimensions

Fe ¹⁾	=	0.10	
delta L	=		

CHAMBER MINI
Lengths

L1 *	=	46.16	
L2 *	=	48.85	
L3 ¹⁾	=	57.30	

Breech

R	=	1.30	
R1	=	12.00	
R2	=		
R3	=		
r	=		

Powder Chamber

E	=	3.19	
P1 ¹⁾	=	11.97	
P2 *	=	10.98	

Junction Cone

alpha ¹⁾	=	38°19'58"	
S	=	61.95	
r1 max	=	0.50	
r2	=	0.50	

Collar

H1 *	=	9.11	
H2 ¹⁾	=	9.10	

Commencement of Rifling

G1 ¹⁾ *	=	8.24	
G ¹⁾ *	=	35.00	
alpha1	=	90°	
h *	=	0.43	
s	=		
i ¹⁾	=	0°17'11"	
w	=		

Barrel

F ¹⁾ *	=	7.89	
Z ¹⁾	=	8.20	

Grooves

b	=	4.40	
N	=	4	
u	=	240.00	
Q	=	51.78	mm ²

Notes: 1) Check for safety reasons
 * Basic dimensions