

# C.I.P.

## 357 Magnum

Country of Origin: US

TAB. IV

Date 84-06-14

Revision 06-06-14

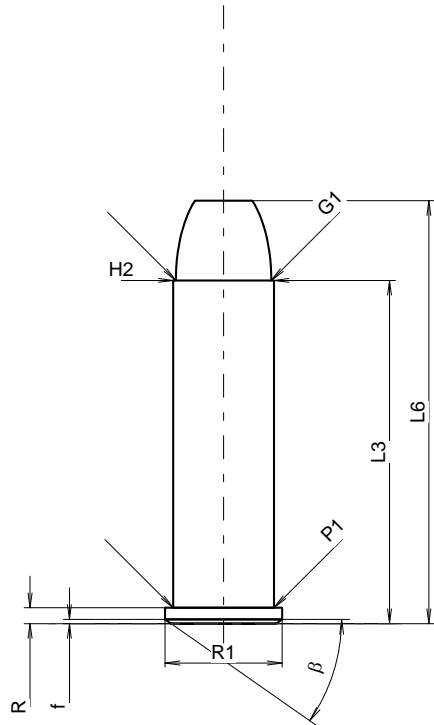

### CARTRIDGE MAXI

#### Lengths

L1	=	
L2	=	
L3 <sup>1)</sup>	=	32.77
L4	=	
L5	=	
L6	=	40.39

#### Case Head

R <sup>1)</sup>	=	1.52	-0.25
R1	=	11.18	
R3	=		
E	=		
E1	=		
e min	=		
delta	=		
f	=	0.40	
beta	=	35°	

#### Powder Chamber

P1	=	9.63
P2	=	

#### Junction Cone

alpha	=	
S	=	
r1 min	=	
r2	=	

#### Collar

H1	=	
H2 <sup>1)</sup>	=	9.63

#### Projectile

G1 <sup>1)</sup>	=	9.12
G2	=	
F	=	
L3+G <sup>1)</sup>	=	43.27

#### Pressures (Energies)

##### Method Transducer

Pmax	=	3000 bar
PK	=	3450 bar
PE	=	3900 bar
M	=	17.50

#### Miscellaneous Dimensions

Fe <sup>1)</sup>	=	0.25
delta L	=	

### CHAMBER MINI

#### Lengths

L1	=	
L2	=	
L3 <sup>1)</sup>	=	33.07

#### Breech

R <sup>1)</sup>	=	1.52
R1	=	11.28
R2	=	
R3	=	
r	=	

#### Powder Chamber

E	=	
P1 <sup>1)</sup>	=	9.68
P2	=	

#### Junction Cone

alpha	=	
S	=	
r1 max	=	
r2	=	

#### Collar

H1	=	
H2 <sup>1)</sup>	=	9.65

#### Commencement of Rifling

G1 <sup>1)</sup> *	=	9.09
G <sup>1)</sup>	=	10.50
alpha1 *	=	13°
h	=	2.46
s	=	8.69
i <sup>1)</sup> *	=	4°45'
w	=	

#### Barrel

F <sup>1)</sup> *	=	8.79
Z <sup>1)</sup>	=	9.02

#### Grooves

b	=	2.69
N	=	6
u	=	476.00
Q	=	62.57 mm <sup>2</sup>

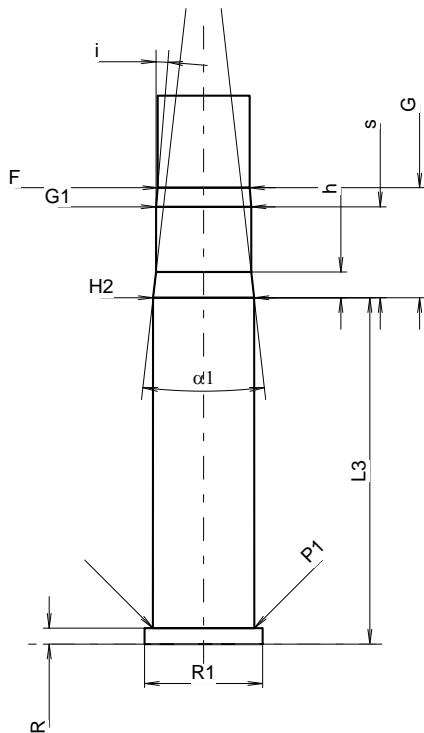

Scale 1.39:1

Dimensions in << mm >>  
Dimensions and Tolerances for Proof Barrels  
see Appendix CR 1.

Notes: 1) Check for safety reasons  
\* Basic dimensions